

Perzeptive Farbsensoren PCS-B (Festoptik) PCS-B-F (Lichtleiteranschluss)/

*Perceptive Color Sensors
PCS-B (fixed optic)
PCS-B-F (fiber connector)*



Silicann Technologies GmbH
Joachim-Jungius-Str. 9
18059 Rostock

Tel: +49 (381) 4059 – 760
Tel: +49 (381) 4059 – 874

www.silicann.com

I Elektrische Anschlüsse/ *Electrical interfaces*

Die elektrischen Anschlüsse des Sensors zeigt Fig. 1./
The electrical connections of the sensor shows Fig. 1.

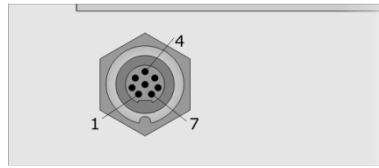

Fig. 1 Elektrische Anschlüsse am Sensor/ *Electrical interfaces*

Tab. 1 Bedeutung der Signale an Sensorbuchse

Pin (color)	Name	Bedeutung/ <i>Description</i>
1 (weiß/ <i>white</i>)	CH1	Schaltausgang (Kanal) 1/ <i>Switching output (Channel) 0</i>
2 (braun/ <i>brown</i>)	CH2	Schaltausgang (Kanal) 2/ <i>Switching output (Channel) 1</i>
3 (grün/ <i>green</i>)	TRG1	Tastensperre/ <i>Key lock</i>
4 (gelb/ <i>yellow</i>)	TRG0	1. Eingang zur Aktualisierung der Sensorausgänge (steigende Flanke) im „Ext. Trigger“ Modus/ <i>Input for updating the sensor outputs (rising edge) in "Ext. Trigger" mode</i> 2. Eingang für externes Teach-In im „EXT. TEACH“ Modus (steigende Flanke)/ <i>Input for external triggered Teach-In in "EXT. TEACH" mode (rising edge)</i>
5 (grau/ <i>gray</i>)	GPO	Keine Funktion (offen lassen!)/ <i>No function (Left open!)</i>
6 (rosa/ <i>pink</i>)	CH3	Schaltausgang (Kanal) 3/ <i>Switching output (Channel) 3</i>
7 (blau/ <i>blue</i>)	GND	Masseanschluss/ <i>Ground</i>
8 (rot/ <i>red</i>)	+U _B	Betriebsspannung/ <i>Power supply</i>

2 Technische Daten/ *Technical Data*

Tab. 2 Allgemeine Daten/ *General Data*

Fotodetektor/ <i>Photo detector</i>	Dreibereichsfotodiode/ <i>Three range photo diode</i>
A/D Umsetzung/ <i>A/D Conversion</i>	3 x 12 Bit
Objektbeleuchtung/ <i>Object illumination</i>	Weißlicht-LED/ <i>White light LED</i>
Anschlüsse/ <i>Connectors</i>	<ul style="list-style-type: none"> • 3 Schaltausgänge/ <i>3 Switching outputs (Gegentakt/ Push-Pull)</i> • 2 Steuereingänge/ <i>2 control inputs</i>
Bedientasten/ <i>Operating buttons</i>	<ul style="list-style-type: none"> • 1 SET Taste/ <i>1 SET button</i> • 3 Farbkanaltasten/ <i>3 Color channel buttons</i>
Anzeigen/ <i>Displays</i>	<ul style="list-style-type: none"> • 3 LEDs (integriert in Kanaltasten/ <i>Integrated in channel buttons</i>) • 1 SET LED
Farbauflösung/ <i>Color resolution (L*a*b*)</i>	DE _{Lab} ≤ 1
Ansprechzeiten/ <i>Response Time</i>	10 ms, 1 ms, (500 µs, 100 µs)*
Schutzart/ <i>Protection standard</i>	IP54
Stromversorgung/ <i>Power supply</i>	18-28 VDC, 100 mA
Gehäusetemperatur im Betrieb/ <i>Case temperature for operation</i>	-10...55°C

* „Printmark“ Version

Tab. 3 Funktionen/ Functionality

Schaltausgänge/ <i>Switching outputs</i>	3
Farbspeicher/ <i>Color memory cells</i>	3
Ausgangshaltezeit/ <i>Output hold time</i>	10 ms (0 ms)*
Hysterese/ <i>Hysteresis</i>	30%
Farbraummodus/ <i>Color space mode</i>	L*a*b*
Betriebsmodi/ <i>Operating modes</i>	<ul style="list-style-type: none"> • Externes Einlernen/ <i>External teach-in</i> • Farberkennungsmodus/ <i>Color recognition mode</i> (Farbprüfung od. Klassifikation/ <i>Check or Classification</i>) • Tastensperre/ <i>Key lock</i> • Abtastrate umschalten/ <i>switch scan rate</i> • Externe Triggerung/ <i>External triggering</i>

Tab. 4 Optische Daten PCS-B/ Optical Data PCS-B

Arbeitsabstand/ <i>Working distance</i>	• 30-60 mm
Messfleckdurchmesser/ <i>Spot diameter</i>	• ca./ <i>approx.</i> 5-13 mm
Fremdlichtunterdrückung/ <i>Ambient light suppression</i> ¹	• min. 2000 lx

1) Arbeitsabstand: 40 mm, Objekt: Signalweiß (RAL9003)/ *Working distance 40 mm, Object: signal white (RAL9003)*

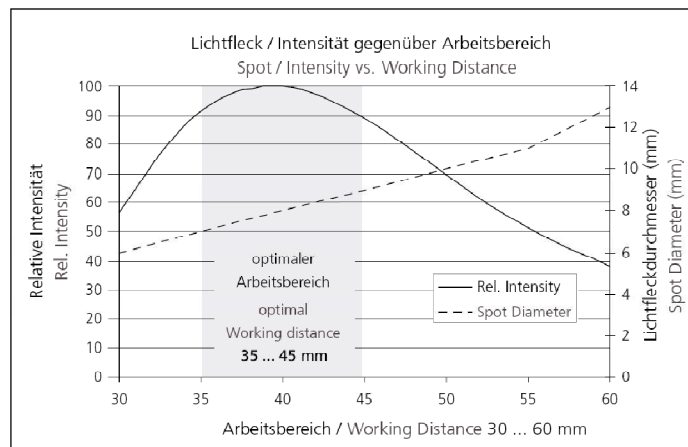

Fig. 2: Messfleckdurchmesser und relative Intensität in Abhängigkeit des Arbeitsabstands PCS-B/ Spot diameter and relativ intensity vs. working distance PCS-B

Tab. 5 Mechanische Daten PCS-B/ Mechanical Data PCS-B

Gehäusematerial/ <i>Housing material</i>	Alu, eloxiert/ <i>Aluminum, anodized</i>
Maße/ <i>Housing size</i>	50x50x21,0 mm ³
Gewicht/ <i>Weight</i>	ca. 80 g

Tab. 6 Optische Daten PCS-B-F/ Optical Data PCS-B-F

Messsignaleinkopplung/ <i>Coupling in measurement signal path</i>	per Lichtwellenleiter/ <i>Via optical fiber</i>
Objektbeleuchtung/ <i>Object illumination path</i>	per Lichtwellenleiter/ <i>Via optical fiber</i>
Lichtquelle/ <i>Illuminant</i>	Weißlicht-LED/ <i>White light LED</i>

Tab. 7 Mechanische Daten PCS-B-F/ Mechanical Data PCS-B-F

Gehäusematerial/ <i>Housing material</i>	Alu, eloxiert/ <i>Aluminum, anodized</i>
Maße/ <i>Housing size</i>	50x50x21,0 mm ³
Gewicht/ <i>Weight</i>	ca. 80 g
Faseranschluss/ <i>Fiber Connector</i>	M18x1

* "Printmark" Version

3 Zeichnungen/ Drawings

3.1 PCS-B

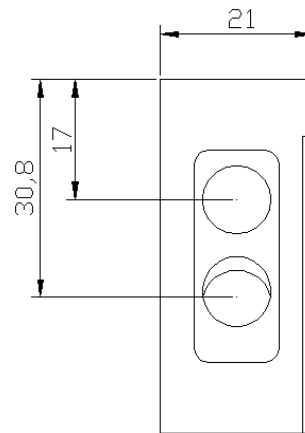
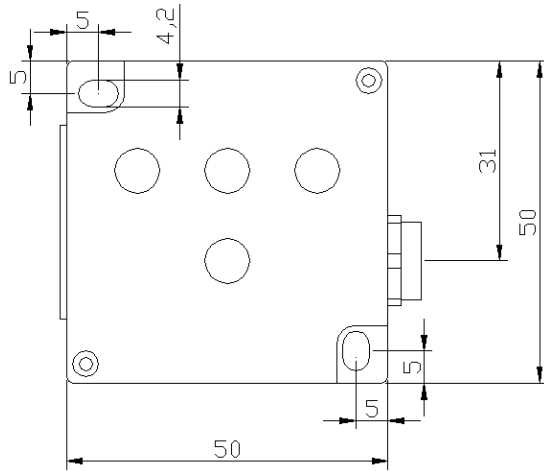

3.2 PCS-B-F

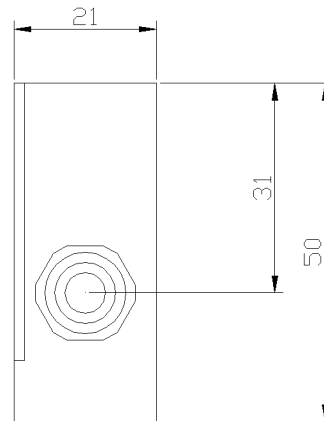
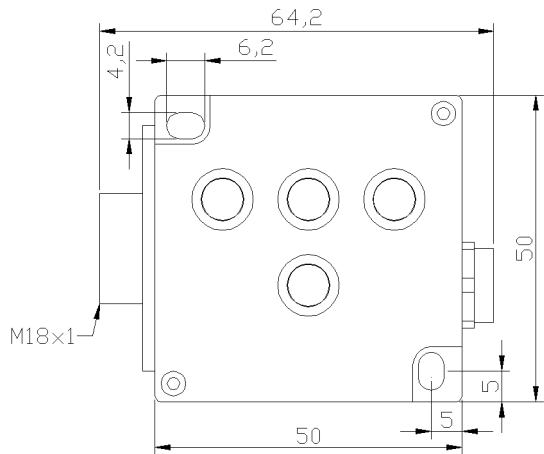

4 Elektrische Anschlüsse/ *Electrical connectors*

Die Zählweise für die PINs der 8-poligen Rundbuchse können Fig. 3 entnommen werden./
The counting order of the 8-pin round connector is shown in Fig. 3.

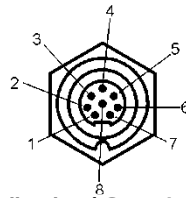

Fig. 3: Zählweise der 8-poligen Rundbuchse/ *Counting order of the 8-pin round connector*

Tab. 8 Sensorbuchse/ *Sensor connector SBI*

Pin	Spezifikation/ <i>Specification</i>
1 (CH1)	LOW: 0V; HIGH: +U _B -1V; max. 100 mA
2 (CH2)	LOW: 0V; HIGH: +U _B -1V; max. 100 mA
3 (TRG1) (flankengesteuert/ <i>edge triggered</i>)	LOW: 0...3V; HIGH: 18...28V
4 (TRG0) (flankengesteuert/ <i>edge triggered</i>)	LOW: 0...3V; HIGH: 18...28V
5 (GPO)	LOW: 0V; HIGH: +U _B -1V; max. 100 mA
6 (CH3)	LOW: 0V; HIGH: +U _B -1V; max. 100 mA
7 (GND)	0 V
8 (+U _B)	18-28 VDC, 100 mA

5 Bedienung/ *Operation*

5.1 Farbe einlernen/ *Teaching in colors*

- Sensor an Objekt ausrichten/ *Position sensor to object*
- „SET“ Taste drücken („SET“ Taste leuchtet)/ *Press „SET“ button (“TOL” button is shining)*
- Gewünschte Kanaltaste (z.B. CH1) min. 2 sec. drücken/ *Press corresponding channel button (e.g. CH1) for at least 2 sec.*
- Optional Toleranz anpassen (siehe 5.2)/ *optionally adjust tolerance (see 5.2)*
- “SET” Taste zum Speichern und Verlassen des Teach-Modus kurz drücken/ *Press „SET“ button to store and exit teach mode shortly*

5.2 Toleranz anpassen/ *Adjust tolerance*

- „SET“ Taste drücken (“SET” Taste leuchtet)/ *Press “SET” button (“SET” button is shining)*
- entsprechende Kanaltaste mehrfach drücken, bis Toleranzwert erreicht ist *Repeat pressing corresponding channel button until tolerance value is reached*
- “SET” Taste zum Speichern und Verlassen des Teach-Modus kurz drücken/ *Press „SET“ button to store and exit teach mode shortly*

Blinkimpulse/ <i>flash impulses</i>	Toleranz/ <i>Tolerance</i>	Toleranzwert/ <i>Tolerance value</i>
1	Sehr klein/ <i>very small</i>	3
2	Klein/ <i>small</i>	6
3	Mittel/ <i>medium</i>	9
4	Groß/ <i>large</i>	15
5	Sehr groß/ <i>very large</i>	20

5.3 Gesamte Farbtabelle löschen/ *Delete entire color table*

- „SET“ Taste kurz drücken (“SET” Taste leuchtet)/ *Press “SET” button shortly (“SET” button is shining)*
- „SET“ Taste min. 2 sec. drücken/ *Press „SET“ button for at least 2 sec.*

5.4 Sende-LED automatisch aussteuern/ *Auto-Adjust send-LED*

- Sensor an (hellstem) Objekt ausrichten/ *Position sensor to (brightest) object*
- „SET“ Taste drücken („SET“ Taste leuchtet)/ *Press „SET“ button (“TOL” button is shining)*
- Belibige Kanaltaste (z.B. CH1) min. 4 sec. drücken/ *Press any channel button (e.g. CH1) for at least 4 sec.*
- “SET” Taste zum Speichern und Verlassen des Teach-Modus kurz drücken/ *Press „SET“ button to store and exit teach mode shortly*

Hinweis/ *Note:*

Bei Übersteuerung des Sensors blinken die Tasten-LEDs alternierend!
If the sensor signal is clipping the Button-LEDs are flashing alternately!

5.5 Boot-Up Konfiguration/ *Boot-Up configuration*

Zum Aktivieren der Boot-Up Konfiguration halten Sie die SET-Taste beim Einschalten der Stromversorgung gedrückt./

For activating the Boot-up configuration please hold the SET-button while powering the sensor.

Taste/ <i>button</i>	LED	Konfiguration/ <i>Configuration</i>
CH1	Aus/ <i>Off</i>	Teach-In aktiv/ <i>teach-in active</i>
	Ein/ <i>On</i>	Ext. Trigger Modus aktiv/ <i>ext. trigger mode active</i>
CH2	Aus/ <i>Off</i>	Farberkennung "Prüfen" aktiv/ <i>Check mode active</i>
	Ein/ <i>On</i>	Farberkennung "Klassifikation" aktiv/ <i>classification mode active</i>
CH3	Aus/ <i>Off</i>	Langsamer Abtastmodus 100 Hz (2 kHz)*/ <i>Low scan rate mode</i>
	Ein/ <i>On</i>	Schneller Abtastmodus 1 kHz (10 kHz)*/ <i>High scan rate mode</i>
SET	Aus/ <i>Off</i>	Zum Verlassen min. 2sec. drücken/ <i>Press min. 2 sec. for exit</i>
	Ein/ <i>On</i>	Boot Menü aktiv/ <i>Boot menu active</i>

* „Printmark“ Version

Zum Verlassen des Boot Menüs die SET Taste für min. 2 sec. gedrückt halten./ *For exiting the Boot menu please hold the SET button for at least 2 sec.*

5.6 Tastensperre aktivieren/ *Set key lock*

Zum setzen der Tastensperre TRG1 (PIN 3, grüne Leitung) auf +Ub schalten./

For setting the key lock please connect TRG1 (PIN3, green wire) with positive power supply.

6 Montagewinkel/ *Mounting Bracket*

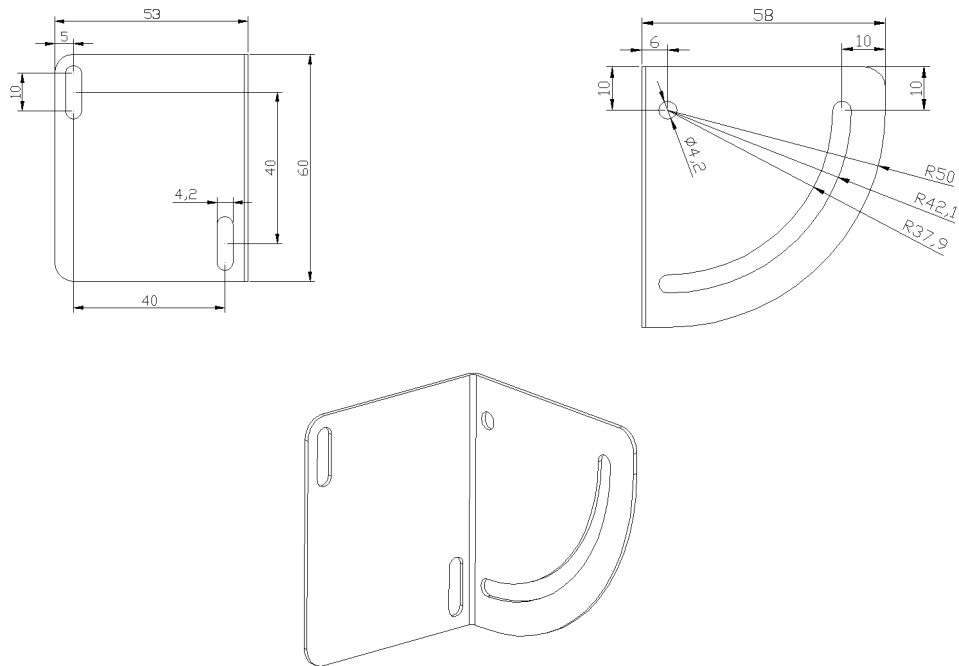

7 Bestellnummern/ *Ordering numbers*

Artikel/ <i>Item</i>	Bestellnummer/ <i>Order Number</i>
PCS-B	11-1003-01
PCS-B-F	11-1003-02
PCS-B "Printmark"	11-1003-03
PCS-B-F "Printmark"	11-1003-04
Montagewinkel/ <i>Mounting Bracket</i>	21-0003-01
8 pol. Anschlusskabel/ <i>8-way connector cable, 2m</i>	13-1000-01
Schutzkappe/ <i>Protection cap</i>	13-1003-02
Lichtleiter/ <i>Fiber optics</i>	Lichtleiterprospekt/ <i>fiber optics brochure</i>



Sicherheitshinweise

Diese Geräte sind nicht zulässig für Sicherheitsanwendungen, insbesondere bei denen die Sicherheit von Personen von der Gerätefunktion abhängig ist. Der Einsatz der Geräte muss durch Fachpersonal erfolgen.

Reparatur nur durch Silicann Technologies.



Safety instructions

The instruments are not to be used for safety applications, in particular applications in which safety of persons depends on proper operation of the instruments.

These instruments shall exclusively be used by qualified personnel.

Repair only by Silicann Technologies.